



Series 5000SS

Reduced Pressure Detector Assemblies

Sizes: 2½" – 6" (65 – 150mm)

Features

- Stainless steel construction provides long term corrosion resistance and maximum strength
- Stainless steel body is light weight reducing installation and shipping costs
- Short end to end dimensions makes retrofit easy
- Bottom mounted relief valve reduces clearance requirements when installed against an outside wall
- Patented cam-check valves provides maximum flow at low pressure drop
- No special tools required for servicing
- Compact construction allows for smaller enclosures
- Stainless steel relief valve features a balanced rolling diaphragm to eliminate sliding seals and lower maintenance costs
- Detects underground leaks and unauthorized water use.
- GPM or CFM meter available

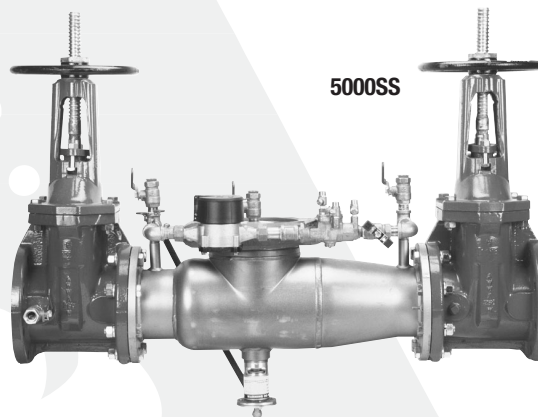

Series 5000SS Reduced Pressure Detector Assemblies patent #5,046,525 are designed for use in accordance with water authority-containment programs. This series can be used to prevent the reverse flow of health hazard fire protection substances, i.e., glycerin wetting agents, foam agents, stagnant water, auxiliary supplies and water of non-potable quality from being pumped or siphoned into the potable water supply.

Available Models

Suffix:

- LG - less gates
- OSY - UL/FM outside stem and yoke resilient seated gate valves
- *OSY FxG – flanged inlet gate connection and grooved outlet gate connection
- *OSY GxF – grooved inlet gate connection and flanged outlet gate connection
- *OSY GxG – grooved inlet gate connection and grooved outlet gate connection
- ¾" Bypass Line:
 - CFM - cubic feet per minute meter
 - GPM - gallons per minute meter
 - LM - less meter

Available with grooved NRS gate valves - consult factory*

Post indicator plate and operating nut available – consult factory*

*Consult factory for dimensions

Note: The installation of a drain line is recommended. When installing a drain line, an air gap is necessary.

Specifications

A Reduced Pressure Detector Assembly shall be installed at each cross-connection to prevent backsiphonage and backpressure of hazardous materials into the potable water supply. The assembly shall consist of a pressure differential relief valve located in a zone between two positive seating cam-check valves. The main valve body shall be manufactured from 300 Series stainless steel for corrosion resistance. The cam-check valves shall be of thermoplastic construction with stainless steel hinge pins, cam arm, and cam bearing. The cam-check valve shall utilize a single torsion spring design to minimize pressure drop through the assembly. The cam-check valves shall be modular and shall seal to the main valve body by the use of an O-ring. There shall be no brass or bronze parts used within the cam-check assembly or relief valve. The use of seat screws to retain the check valve seat is prohibited. All internal parts shall be accessible through a single cover on the valve assembly securely held in place by a two-bolt grooved coupling. The differential relief valve shall be of stainless steel construction and shall utilize a rolling diaphragm and no sliding seals. The relief valve shall be bottom mounted and supplied with a steel reinforced sensing hose. The assembly shall include two resilient shutoff valves and four ball type test cocks and a hydraulically balanced by-pass line. The bypass line shall include a meter, small diameter reduced pressure zone assembly and isolation valves. The bypass reduced pressure assembly shall have a single bolted on cover and top mounted test cocks. The assembly shall be an Ames Company Series 5000SS.

Job Name _____ Contractor _____

Job Location _____ Approval _____

Engineer _____ Contractor's P.O. No. _____

Approval _____ Representative _____

Ames product specifications in U.S. customary units and metric are approximate and are provided for reference only. For precise measurements, please contact Ames Technical Service. Ames reserves the right to change or modify product design, construction, specifications, or materials without prior notice and without incurring any obligation to make such changes and modifications on Ames products previously or subsequently sold.

Materials

- All internal metal parts: 300 Series stainless steel
- Main valve body: 300 Series stainless steel
- Check assembly: Noryl®
- Flange dimension in accordance with AWWA Class D

Pressure — Temperature

Temperature Range: 33°F – 110°F (5°C – 43°C)
 Maximum Working Pressure: 175psi (12.06 bar)

Standards

AWWA C511-92

Approvals



IMPORTANT: INQUIRE WITH GOVERNING AUTHORITIES FOR LOCAL INSTALLATION REQUIREMENTS

Noryl® is a registered trademark of General Electric Company.

Dimensions — Weights

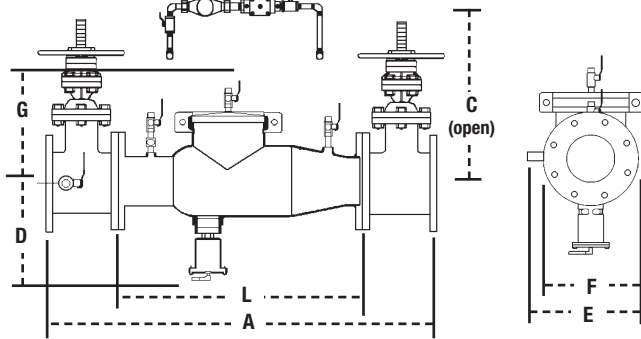

SIZE (DN)		DIMENSIONS										WEIGHTS							
		A		C (OSY)		D		E		F		G		L		with Gates		without Gates	
in.	mm	in.	mm	in.	mm	in.	mm	in.	mm	in.	mm	in.	mm	in.	mm	lbs.	kgs.	lbs.	kgs.
2½	65	37	940	16¾	416	10½	267	12½	318	7	178	10	254	22	559	170	77	61	28
3	80	38	965	18⅞	479	10½	267	13	330	7½	191	10	254	22	559	205	93	65	29
4	100	40	1016	22¾	578	10½	267	14½	368	9	229	10	254	22	559	270	122	67	30
6	150	48½	1232	30⅞	765	11½	292	15½	394	11	279	11½	292	27½	699	405	184	105	48

Capacity

*UL Rated **UL Tested

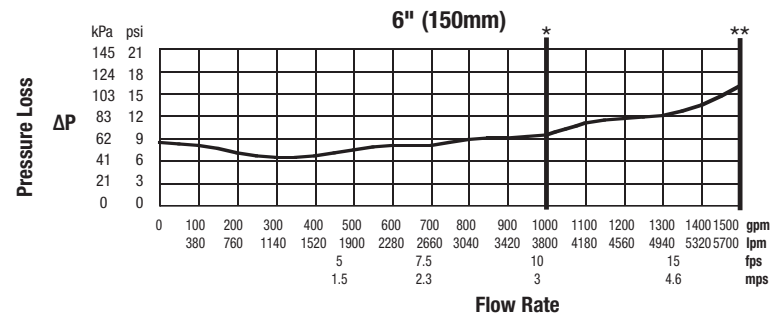
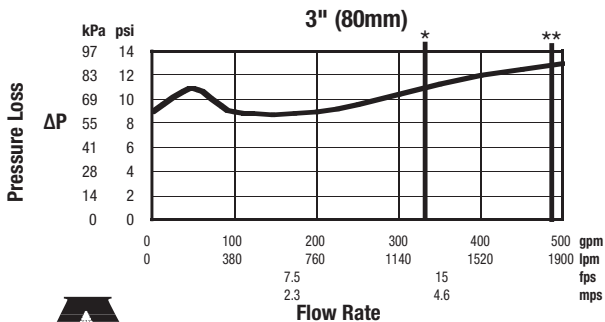
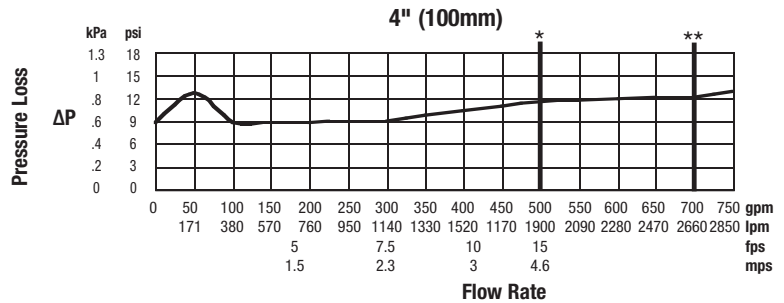
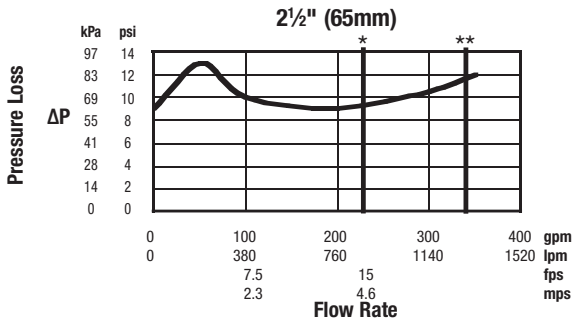

A Division of Watts Regulator Company

www.amesfirewater.com



1427 North Market Blvd. • Suite #9 • Sacramento, CA 95834 • Phone: 916-928-0123 • Fax: 916-928-9333